



Converter Accessory Corporation
www.converteraccessory.com



Core Locking / Holding Systems
www.cor-lok.com



COR-LOK® Aluminum Core Cones

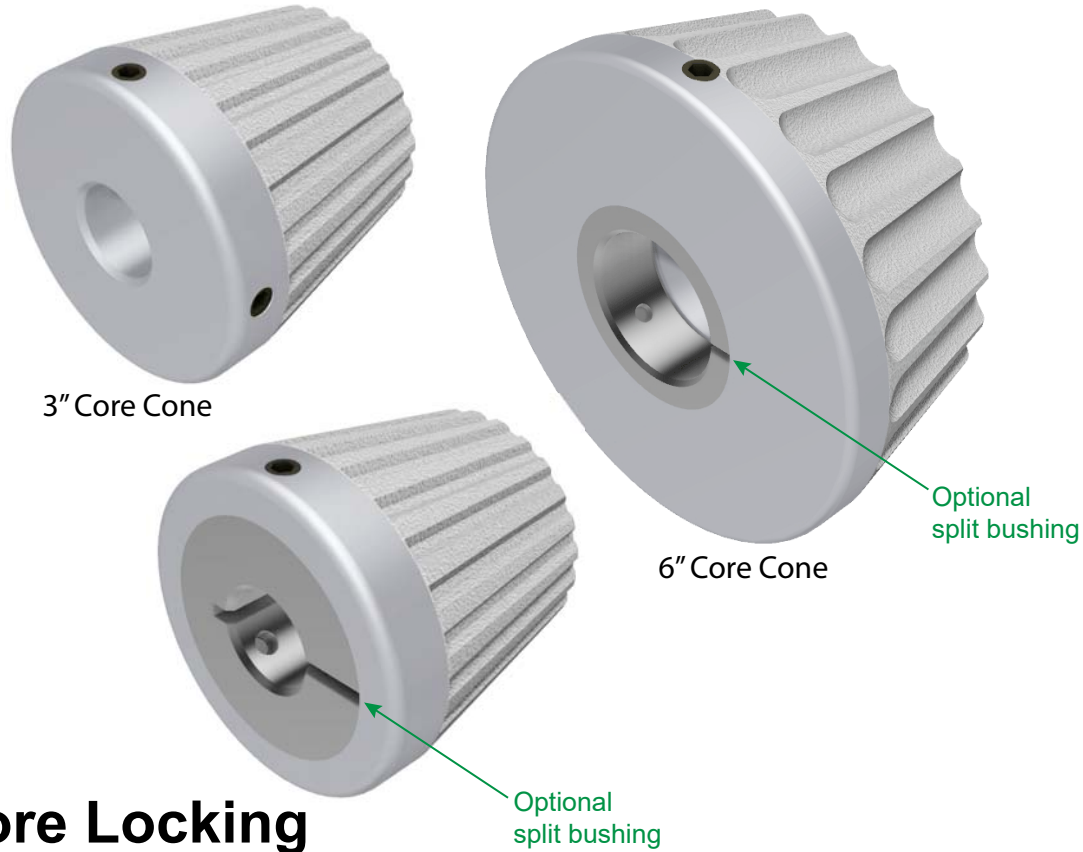

Inexpensive Core Locking

COR-LOK aluminum core cones are the answer where initial low cost and infrequent roll changes are important. **They work extremely well for crushed cores.** Core cones are bored to easily slide on your thru shaft. They include 2 set screws located 90 degrees apart to lock in place anywhere along your thru shaft. **Split bushings are optional to allow locking to your thru shaft without the set screws coming in contact with the shaft.**

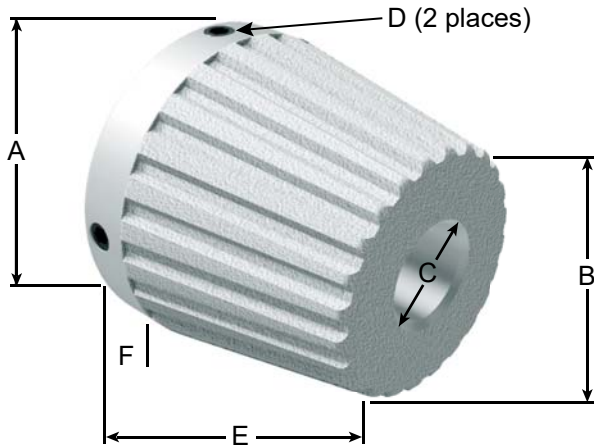

To fit core size	A	B	C	D	E	F
	Major diameter	Minor diameter	Bore range	Set screw	Overall length	Land
3	3-3/8	2-1/2	Up to 2-1/4	3/8-16	3-1/8	5/8
6	6-5/8	5-1/2	Up to 5-1/4	1/2-13	3-1/8	5/8

Note: All dimensions in inches. Thru bores machined .010" - .015" oversized unless otherwise specified.



www.converteraccessory.com
sales@converteraccessory.com

Converter Accessory Corporation

201 Alpha Road, PO Box 188, Wind Gap, PA 18091-0188

Phone: 800-433-2413
610-863-6008

Fax: 800-709-1007
610-863-7818